

Tobacco Machinery Chains

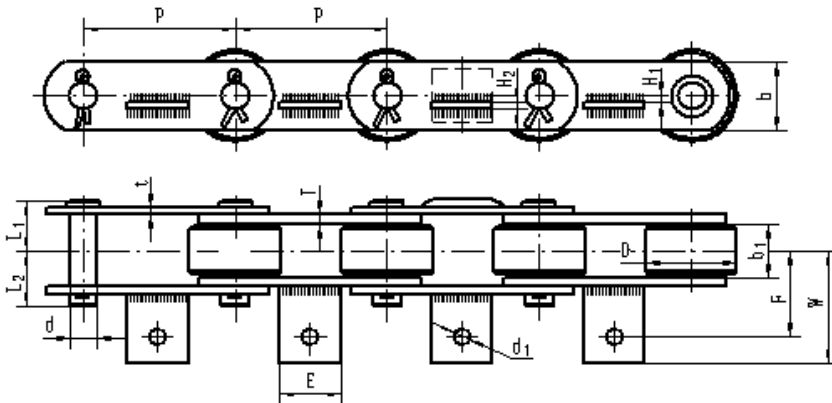

Chain No.	H ₁ mm	H ₂ mm	F mm	W mm	d ₁ mm	E mm
BKC100	3	5	55	73	11	40
BKC100CC	4	5	55	73	11	40
BKC150	8	5	41	55	9	85

Chain No.	P mm	b 1(min) mm	D(max) mm						Q _{min} kN	Rated working load kN	q kg/m
				d mm	L 1 mm	L2 mm	h mm	t/T mm			
BKC100	100	35	60	18	33.2	35.8	45	5/6	150	13.64	11.26
BKC100CC	100	35	60	18	33.2	35.8	45	5/6	150	13.64	11.26
BKC150	150	30	50	14	29.7	35.1	45	5	150	13.64	20.17

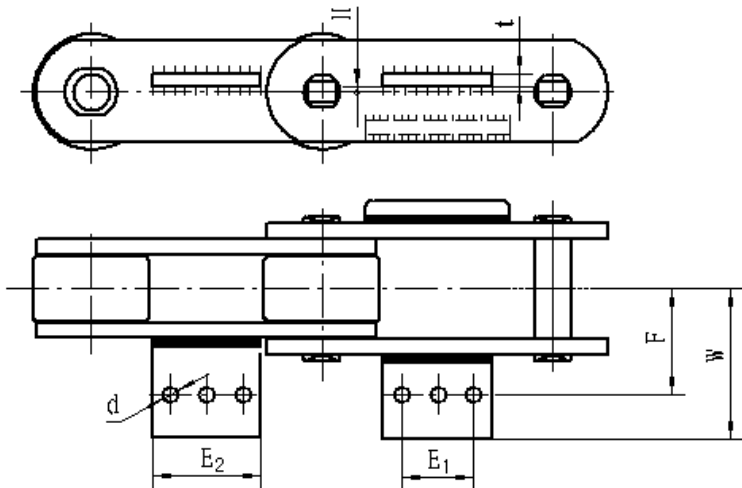

Type	Chain No.	E ₁	E ₂	t	H	F	W	d
A3	BKC100G	35	50	5	6	55	83.5	9
A3	BKC160	50	75	8	4	73	93.2	11
A3	BKC160G	50	75	8	5	73	103.2	11

Q_{min} KN = Ultimate tensile strength

Tobacco Machinery Chains

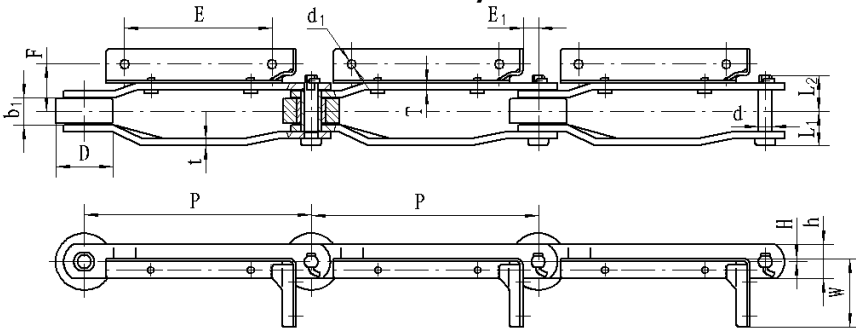

Chain No.	E	E ₁	W	F	d ₁	H
BKC200L/R	130	13.9	60	41.6	7	2.5
BKC203.2L/R	127	7.8	62	42.6	8	2

Chain No.	P mm	b 1(min) mm	D(max) mm						Q(min) kN	Rated working load kN	q kg/m
				d mm	L 1 mm	L2 mm	h mm	t/T mm			
BKC200L/R	200	24	50	12	29.3	32	30	6	130	12.5	5.99
BKC203.2L/R	203.2	24	50	12	29.3	32	30	6	130	12.5	5.97

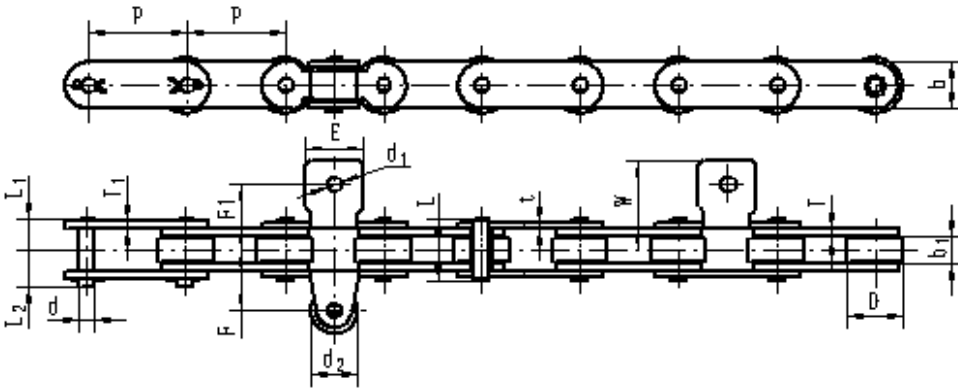

Chain No.	F	F ₁	W	E	d ₁	d ₂
C2082H-K1F	32	33	46	30	8.5	24

Chain No.	P mm	b1 (min) mm	D(max) mm								Q(min) kN	Rated working load kN	q kg/m
				d mm	L mm	L ₁ mm	L2 mm	h mm	t/T mm	T1 mm			
C2082H-K1F	50.8	15.75	28.58	7.92	35.7	17.85	20.65	23.6	4	4	55.6	5.3	3.75

Q_{min} KN = Ultimate tensile strength